



Alfie 200 for cost-effective cleaning of coolants

Separator system

Alfie 200 is specially designed to remove contaminants from coolants in smaller systems, using the time-tested technique of centrifugal separation.

Alfie 200 is a small, compact unit, mounted on a frame and equipped with a plate that is screwed to the coolant tank. Under the separator is a bellows that automatically adapts the inlet to the level of fluid in the tank.

Alfie 200 is extremely easy to use. Anyone can learn all that is needed to operate and maintain Alfie in a few minutes.

Innovative

Thanks to new materials and new design solutions, Alfie 200 is truly compact. Total weight, including the stand, is only 14 kg.

Most essential components traditionally manufactured in stainless steel have been replaced by a recently developed tough, durable plastic.

Simple cleaning

It is fast and easy to clean the separator. The casing is lifted off by hand in a few easy movements and the sediment that has been collected on the periphery of the bowl is brushed off.

- 1 Solid particles accumulate inside the rotating bowl. When the bowl needs to be cleaned, it can be opened with a few simple operations.
- 2 The tramp oil leaves through the centre of the bowl down into a separate collecting tank.
- 3 The adjustable frame is mounted on top of the coolant tank.
- 4 The bellows automatically adapts the inlet to the level of fluid in the tank.
- 5 The purified coolant is returned to the tank through three hoses, which are positioned to create circulation of the fluid.



Alfie 200.



The separator is fed by a conical-shaped centrifugal pump, which is operated by the same electric motor as the separator.

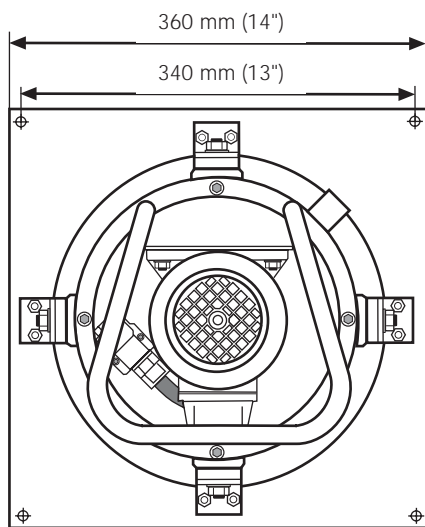

Technical data

Capacity

Max. flow	280 l/h (1.2 US gpm)
Average flow	230 l/h (1 US gpm)
Sludge space	0.6 l (0.16 US gal)

Liquid requirements

Separation temperature	5–50°C (40–122°F)
pH-value	6–9
Working range (height of bellows)	100 mm (4")

Electrical data

Voltage	
50/60 Hz	400/460 V, three-phase
50/60 Hz	200/230 V, three-phase
60 Hz	120 V, single-phase (±5%)
Amperage	10 A

Weight

Complete unit*	14 kg (31 lbs) to lift 10 kg (22 lbs)
----------------	--

* = excl. hand control unit and hoses.

Dimensions

Height of separator	520 mm (20")
Mounting plate	See illustration
Recommended free space above tank	750 mm (30")
Min. tank depth	200 mm (8")

Alfie 200 is delivered complete with stand, hoses, tools and instruction book.

EFU00038EN 0612

Alfa Laval reserves the right to change specifications without prior notification.

How to contact Alfa Laval

Up-to-date Alfa Laval contact details for all countries are always available on our website at www.alfalaval.com