

Alfa Laval OCM Light 503

A compact separator module for oil cleaning

Introduction

Water and solids present in lube oils reduce the lifetime of machinery and increase the risk of unplanned production stops. Untreated fuel oils reduce the efficiency and the lifetime of engines and turbines while increasing the risk of repair costs.

The OCM Light 503 is a complete separation solution from Alfa Laval that improves the reliability of the oil system and protects the machinery/engine/turbine from serious wear and damage by removing water and solids by centrifugal force from the oil.

Application

- Lubricating oils (ISO VG, turbine, hydraulic, compressor etc.)
- Fuel oils (Marine gas oil, Marine diesel oil)

Benefits

- Plug-and-play installation
- Easy to operate
- High separation efficiency
- Small footprint
- Low operating costs

Design

The module is available with and without heater.

The module without heater consists of the separator, the control cabinet, the feed pump, the flexible hoses, and the alarm sensors. All the components are mounted in an optimally designed frame that can fit even the smallest rooms.

The MIB 503 separator, installed on the OCM Light 503 module, consists of a solids-retaining bowl which can operate both as a purifier and a clarifier. Its unique drive technology is based on an electric motor mounted directly to the bowl, controlled by a frequency converter located in the control cabinet.

The pump (various sizes selectable) installed on the module is a positive displacement pump with constant flow and is connected to the separator through flexible hoses and protected by a strainer.

To secure the correct operation of the separator, a pressure sensor and a level sensor are installed on the module. All



functions and alarms are being handled from the control cabinet which has been designed for simplicity and ease of use.

Distillate fuel may require heating in winter conditions, therefore a configuration with an optional heater is available.

In lube oil configuration, the oil must reach the right temperature before the separation process starts. To accomplish that, a heater, a three-way valve and a temperature sensor are included in the heater module option.

Scope of supply

- MIB 503 separator
- Feed pump
- Flexible hoses
- Control cabinet
- Sensors
- Flow control
- Frame with collecting tank

Options

- Electric heater
- Wheel set
- Drip tray
- Emergency stop box
- Trolley (Valid only for module without heater)

Working principle

In gas oil configuration, the fuel oil is being transferred directly from the pump to the separator. In configuration with heater, a heater and a three way valve are installed between the pump and the separator. The three way valve is being used to run the oil on recirculation until the correct separation temperature is reached.

The separator starts up. When the separator reaches full speed, water is added to establish the appropriate water seal (applicable only for purifier setup). Subsequently, the pump starts up and oil is fed to the separator.

The separation process takes place within the bowl. Due to the centrifugal forces, oil, water and particles are being separated based on their specific gravity. The heavy phases, water and particles, are moving to the periphery of the bowl while the light phase, oil, is moving towards the centre of the bowl.

Water is being drained continuously to the collecting tank of the module. The separated particles need to be cleaned periodically by hand. The clean oil is being pumped by a paring disc out of the separator and from there to the daily service fuel tank or the lube oil tank.

A pressure sensor is installed in the oil outlet after the separator. The pressure sensor triggers an alarm during separation if the water seal interface is lost.

A level sensor is installed on the collecting tank of the module. The level sensor triggers an alarm if the separator overflows.

In configuration with heater, a temperature sensor is installed before the separator. The sensor triggers an alarm when temperature drops below setpoint.

All the sensors are connected to the pump which will stop automatically if there is an alarm. In that case, the alarm lamp in the control cabinet will indicate this.

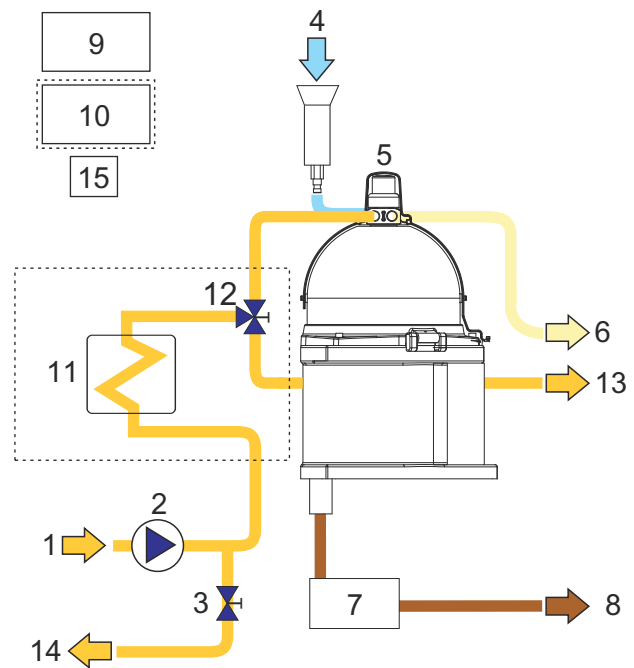

General flow chart of a separator system. The detail may differ slightly between different configurations.

1. Feed inlet
2. Feed pump
3. Flow control valve
4. Water for water seal (only for purifier, only during start-up)
5. Separator
6. Clean oil outlet
7. Collecting tank
8. Drain
9. Control cabinet
10. Power unit (valid only for module with heater)
11. Electric heater (option)
12. Three-way valve (option)
13. Recirculation (option)
14. Oil return
15. Emergency stop box

Technical data

Performance data	
Feed capacities:	
Lube oils	Max. 860 l/h (3.8 US gpm)
Gas oil (1.5 – 6 cSt/40°C)	Max. 1000 l/h (4.4 US gpm)
Marine diesel oil (13 cSt/40°C)	Max. 620 l/h (2.7 gpm)
Power consumption separator and pump	Max. 0.7 kW (0.93 HP)
Electric heater	Max 7 / 14 kW (9.4 / 18.8 HP)
Ambient temperature	Max. 55°C
Feed temperature	Max. 95°C
Voltage	230, 380, 400, 415, 420, 440, 460, 480, 500, 575, 660, and 690V
Voltage with heater	380 – 460 V
Connections	
Feed inlet (1)	G 3/4 inch
Clean oil outlet (6)	G 1/2 inch
Recirculation – heater option (13)	G 1/2 inch
Oil return (14)	G 1/2 inch
Drain (8)	G 1/2 inch

Material data

Separator frame	Surface coated aluminium
Separator bowl	Surface coated aluminium. High-grade polymer composite
Module frame	Structural steel
Gaskets and O-rings	Fluorocarbon rubber (Viton®)

Weights (approximate)

Module without heater (net/gross)	68/98 kg (150/216 lbs)
Module with electric heater (net/gross)	95/130kg (209/287 lbs)

Dimensional drawing

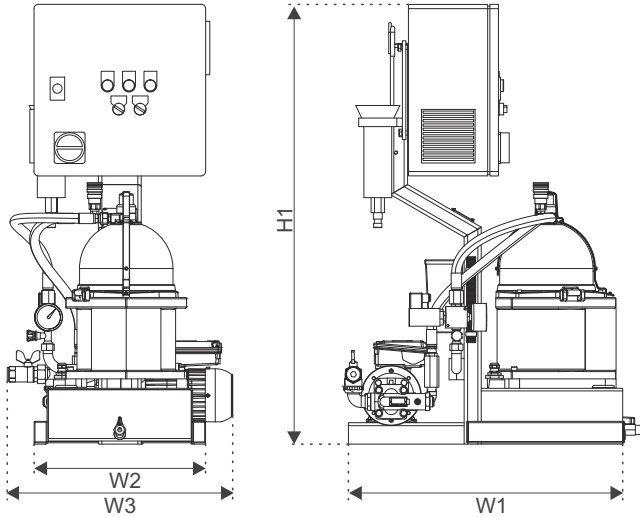

OCM Light 503, height and width

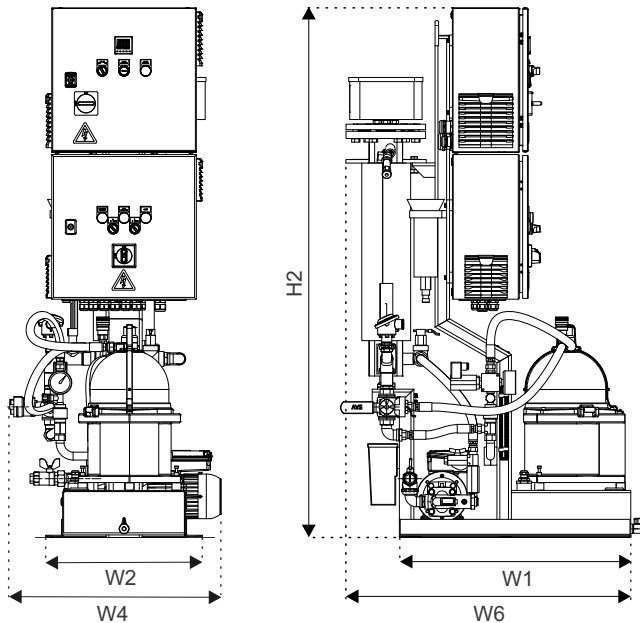

OCM Light 503 with Heatpac EHS-71, height and width

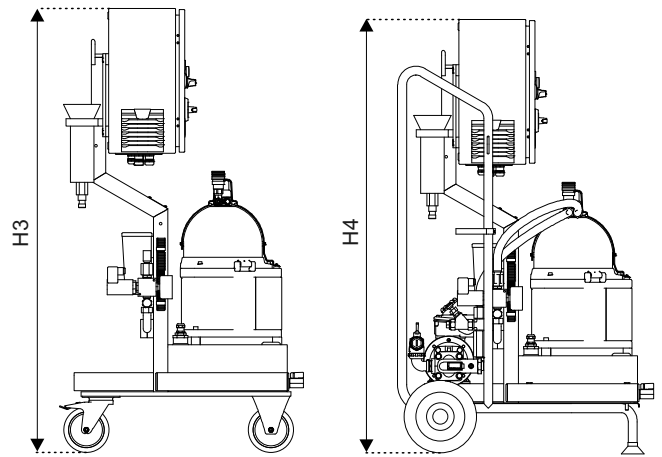

OCM Light 503 with wheels (left) and trolley (right), height

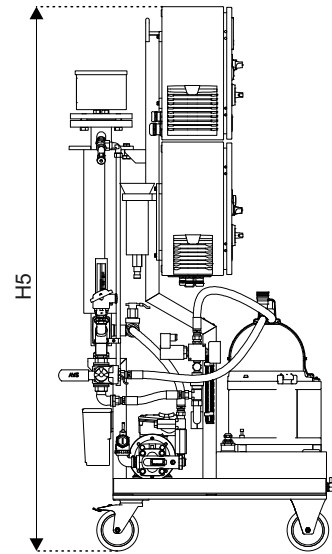

OCM Light 503 with Heatpac EHS-71 and wheels, height

Dimensions

H1	1026 mm (3 ft 4 3/8 inch)
H2	1465 mm (4 ft 10 7/16 inch)
H3	1227 mm (4 ft 5/16 inch)
H4	1198 mm (3 ft 11 11/64 inch)
H5	1632 mm (5 ft 4 1/4 inch)
W1	640 mm (2 ft 1 3/16 inch)
W2	400 mm (1 ft 3 3/4 inch)
W3	525 mm (1 ft 8 11/16 inch)
W4	585 mm (1 ft 11 7/32 inch)
W5	760 mm (2 ft 5 15/16 inch)
W6	770 mm (2 ft 6 11/16 inch)

This document and its contents are subject to copyrights and other intellectual property rights owned by Alfa Laval AB (publ) or any of its affiliates (jointly "Alfa Laval"). No part of this document may be copied, re-produced or transmitted in any form or by any means, or for any purpose, without Alfa Laval's prior express written permission. Information and services provided in this document are made as a benefit and service to the user, and no representations or warranties are made about the accuracy or suitability of this information and these services for any purpose. All rights are reserved.

How to contact Alfa Laval

Up-to-date Alfa Laval contact details for all countries are always available on our website at www.alfalaval.com